

**SEALLESS SLIDING VANE MULTISTAGE
MODULAR PUMP WITH PERMANENT MAGNET
DRIVE SYSTEM, NO MECHANICAL SEAL**



VMODULAR Series

A modular Range of pumps covers the different performances.
The best solution for sampling and low viscosity liquids.

The separation of liquid chamber/atmosphere by means of an isolation shell is the best solution to pump aggressive, explosive and toxic liquids, hydrocarbons, heat transfer liquids and liquids difficult to seal.

The hermetic sealless is the best solution for the chemical, petrochemical and refinery industry.

VMODULAR

PUMP DETAILS

Epoxy primer and polyacrylic enamel water-based painting for the best quality resistance linked to environmental respect.

Different connections are available:
Threaded BSP(GAS) or NPT.

DIN Flanges PN25, PN40, ANSI Class 150, 300 and 600 lbs.

Mounting feet allows to have B3B5 or B5 motor version available.

Between the two stages there is an elastic coupling to absorb unexpected shocks.

This device will also guarantee a longer life for the cartridges. The two Stainless Steel components are achieved by the CNC machining to have the best dimensional accuracy, while the material for the elastomer component used is selected according to the application.

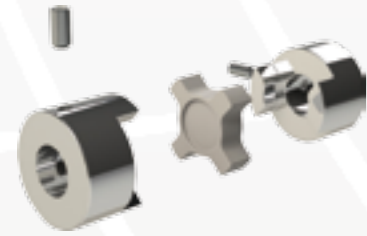

Pump Casing & Cover are made in Stainless Steel 316 solid bar to obtain high quality components within strict tolerances.

A special HP Lip Seal is used to contain the pressure between the two stages.



The sealing system with flat gaskets prevents from leaking to the atmosphere – different materials available:

- Asbestos free
- PTFE (standard)
- Graphoil
- GYLON®

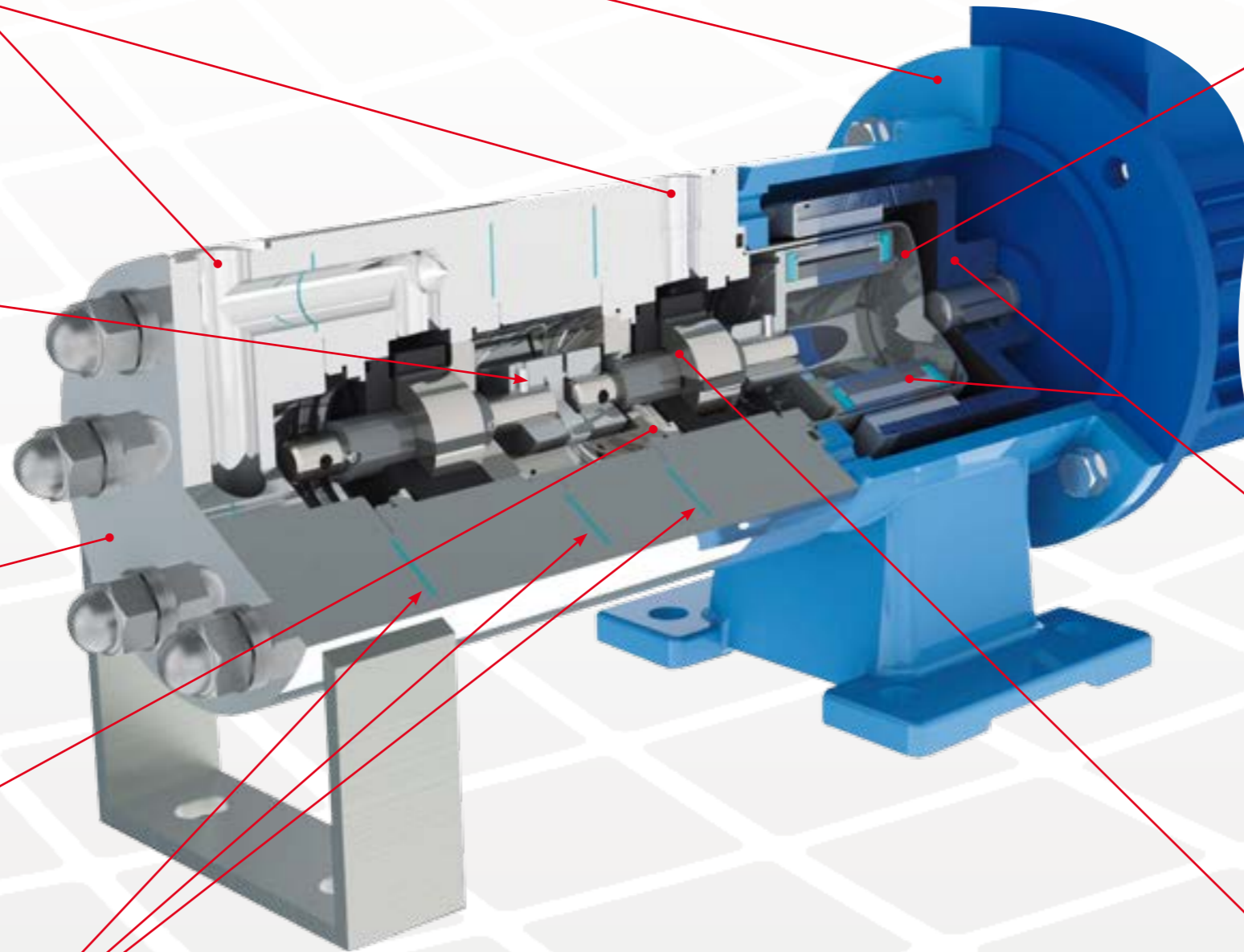

The rear shell is made of one single piece, no welding, ellipsoidal profile that has been studied to withstand higher pressures than the traditional one.

Two versions available, AISI 316 as standard construction, and Hastelloy® C276 for high pressure version - providing a safe and efficient solution – system pressure max 150bar.

Titanium Alloy is an upgrade when higher pressure ratings and increased efficiency are required.



High power synchronous magnetic coupling designed by our Technical Office and with rare earth magnetic elements mechanically locked.

High performance magnets can operate at liquid temperature of up to 392 °F (200°C).

QUICK CHANGE CARTRIDGE KIT to guarantee an easy and fast maintenance.



STANDARD VERSION "1 SiC" (For low viscosity): CARTRIDGE METALLIZED CARBON, ROTOR Duplex 22% Chrome W/SiC BEARINGS.

Pump construction, operating limits and performances

Close-coupled configuration allows conventional drivers to be mounted directly to pump frame. No base, coupling or guards are required for this mounting.

- Connections: Threaded BSP (GAS) & NPT, Flange rating per DIN Norms Class PN25, ANSI B16.5 Class 150, 300 and 600#
- Max viscosity: 10000 cSt
- Max system pressure: 50 bar (standard), 150 bar (HP Version), Higher pressure version available on request.
- Flow up: to 2000 l/h
- Discharged pressure: up to 48 bar
- Temperature: up to +392 °F (+200 °C)
- Electric motors: up to 7,5 kW
- Available ATEX II - / 2G cbk II C T2 - T5

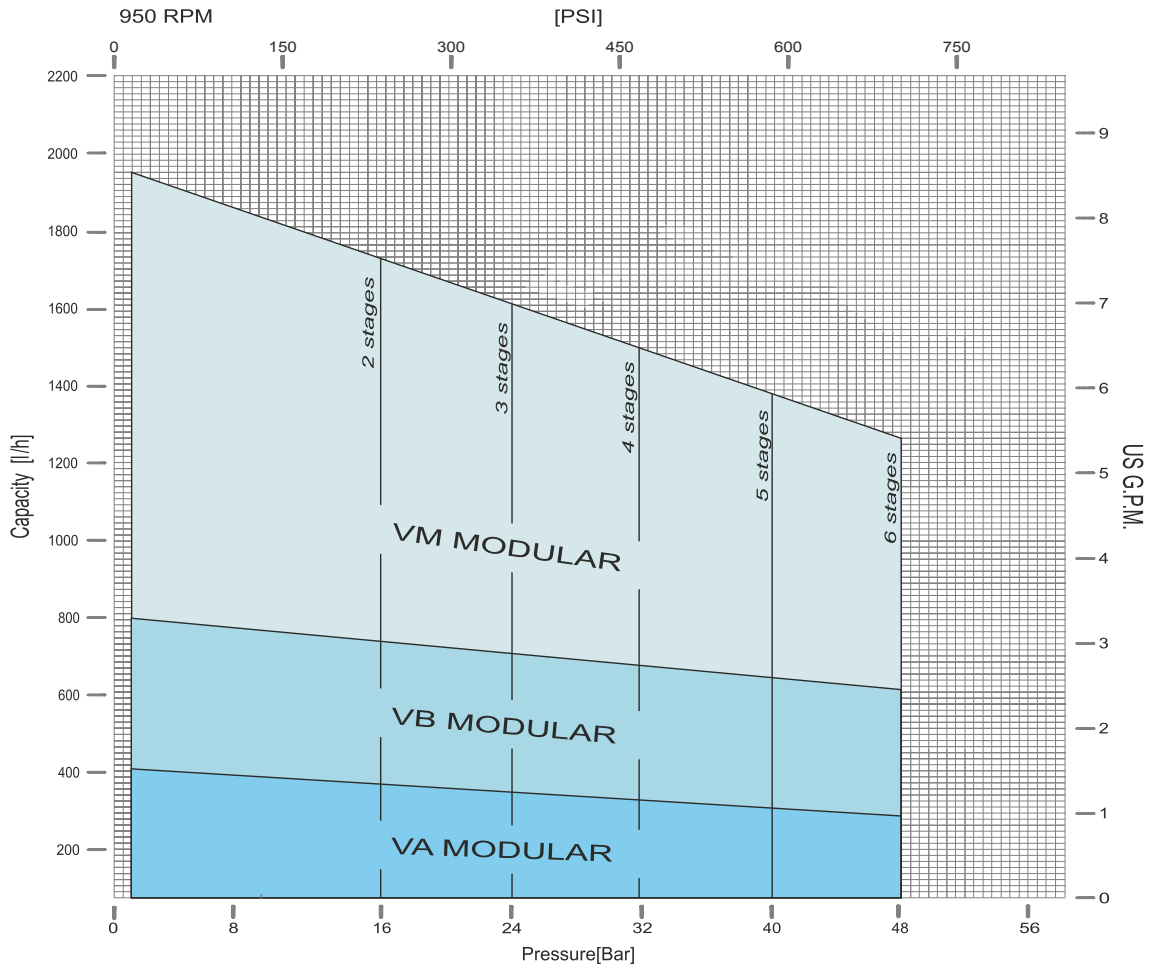

Manufactured by:



A unit of
Mischiatti
GROUP

M PUMPS PROCESS s.r.l. - Via dell'Artigianato, 120
45015 Corbola (Ro) - Italy - www.mpumps.it
Tel. +39 0426 346304 - Fax +39 0426 349126

For more information please contact:

